

DELTACORE WALL PANELS DC 150W AND DC 170W

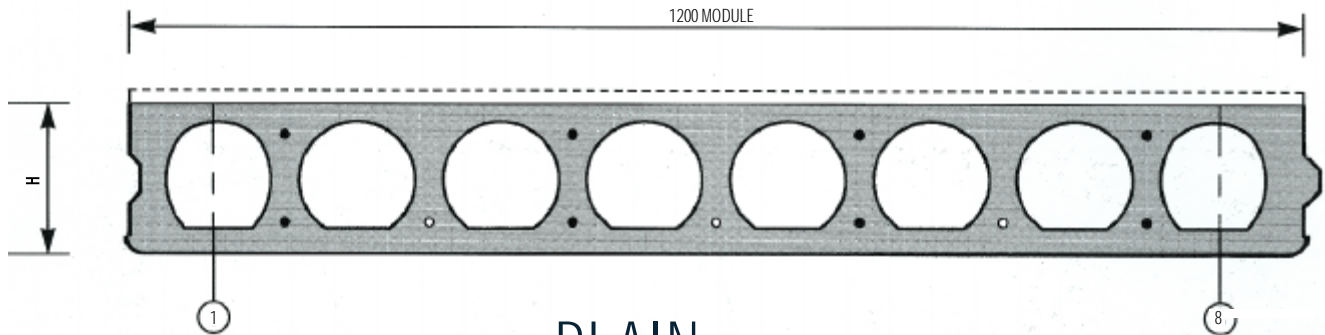

PLAIN

Important: Toppings can be added to achieve coloured and exposed finishes.

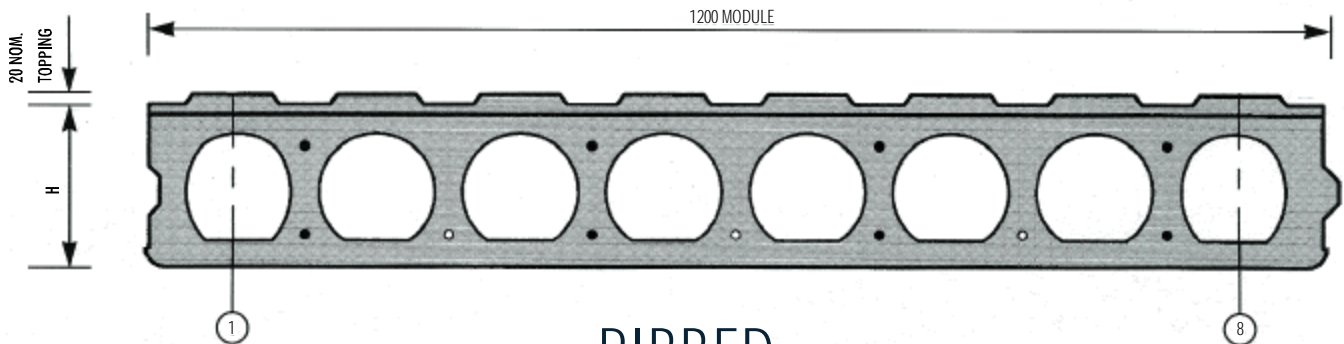

RIBBED

Important: Toppings can be added to achieve coloured and exposed finishes.

DC 150 W							
H (m)	STRANDS	ØMU (kNm)	WEIGHT (kG/M)		MAX HEIGHT (m)	FIRE RATING (Hr)	STC
			Plain	Ribbed			
153	4+4	36.0	250	270	8	1	48
153	3+3	27.0	250	270	7	1	48

DC 170 W							
H (m)	STRANDS	ØMU (kNm)	WEIGHT (kG/M)		MAX HEIGHT (m)	FIRE RATING (Hr)	STC
			Plain	Ribbed			
173	4+4	43.0	310	330	8.5	1.5	48
173	3+3	32.3	310	330	7.5	1.5	48